

PROGRESS TOWARDS NANOMETRE-LEVEL BEAM STABILISATION USING A CAVITY BPM SYSTEM AT ATF2

T. Bromwich, N. Blaskovic Kraljevic, R. M. Bodenstein, P. N. Burrows, G. B. Christian, C. Perry, R. Ramjiawan, John Adams Institute, Oxford, UK

Abstract

A low-latency feedback system has been designed and tested to achieve inter-bunch position stabilisation at the final focus of the Accelerator Test Facility (ATF2) at KEK. This system has now been enhanced through the use of position information from two cavity beam position monitors (BPMs) to enable beam stabilisation at a third, intermediate location where a witness BPM measures the correction. Low-Q cavity BPMs were used, along with custom signal processing electronics designed for low latency and optimal position resolution. A custom stripline kicker, power amplifier and digital feedback board were used to provide beam correction and feedback control. The system was tested in single-pass, multi-bunch mode with the aim of providing inter-bunch beam stabilisation on electron bunches of charge ~ 1 nC separated in time by 280 ns. In 2015 a single BPM feedback system demonstrated beam stabilisation to below 75 nm. To date the two BPM input feedback system has demonstrated beam stabilisation to 83 ± 6 nm. This performance is limited by the current understanding of the cavity BPM resolution. Work will be described with the aim of improving this result.

INTRODUCTION

Fast beam-based feedback systems will be required at future single-pass beamlines such as the International Linear Collider (ILC) [1] to maintain high luminosities. For example, at the interaction point (IP), a system operating on nanosecond timescales can correct within a bunch train to compensate for jitter on the final-focus magnets, steering the electrons and positron beams into collision. A beam position monitor (BPM) can measure deflections in the outgoing beam and the required correction can be calculated and applied to the other incoming beam via a stripline kicker just upstream.

The Feedback On Nanosecond Timescales (FONT) project has developed ILC prototype systems, incorporating digital processors based on Field Programmable Gate Arrays (FPGAs) for use in feedback correction schemes to achieve nanometre-level beam stabilisation at the KEK Accelerator Test Facility (ATF2) [2]. Demonstration of an upstream closed-loop feedback system that meets ILC jitter correction and latency requirements is described in [3], and the optimisation and propagation of this correction along the ATF2 beamline can be found in [4]. Results using a single cavity BPM [5] to drive local feedback correction to below the 75 nm level at the IP using one BPM can be found in [6]. Here we report new results using two cavity BPMs at the IP as input to the feedback system to stabilise the beam position, and independently witness the correction, at a third intermediate BPM.

FONT IP SYSTEM DESIGN

An overview of the ATF2 extraction and final focus showing the location of the FONT components in the IP and upstream regions is given in Fig. 1. A schematic of the two BPM IP feedback set-up is shown in Fig 2. The IP region contains three C-band cavity BPMs (IPA, IPB and IPC) operated on an x, y mover system [8], with IPA and IPC being used in the feedback process described below to correct at the intermediate IPB. The IP feedback correction is applied using a stripline kicker (IPK). The final focus magnets (QF1FF, QD0FF) can be used to steer the beam by introducing a position offset or to move the x and y beam waists longitudinally along the beamline.

A detailed schematic of the hardware is given in Fig. 3. Determining the position of the beam requires the dipole mode signal of the cavity BPMs and the monopole mode of a reference cavity. The cavities were designed so the y-port frequency of both signals is 6.426 GHz [5]. The signals are down-mixed to baseband using a two-stage down-mixer [9], as follows. The first stage mixer takes the 6.426 GHz reference and dipole signals and mixes each with an external, common 5.712 GHz local oscillator (LO) to produce signals at 714 MHz. The reference signal is limited and used as an LO to downmix the dipole 714 MHz signals in the second stage mixers, giving two baseband signals: I (dipole and reference mixed in phase) and Q (dipole and reference mixed in quadrature). The I and Q signals are then digitised in the FONT board and normalised by the bunch charge; the charge is deduced from the amplitude of the reference signal. The charge-normalised I and Q signals are then calibrated against known beam position offsets (by moving BPM movers), allowing the vertical beam position to be determined from a linear combination of charge-normalised I and Q.

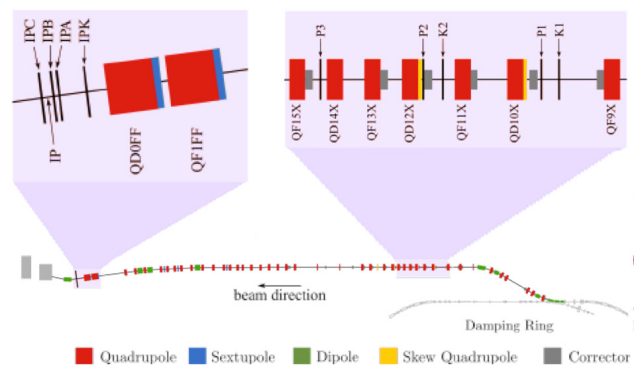

Figure 1: The layout [7] of the ATF2 extraction and final focus with the FONT IP and upstream regions zoomed in.

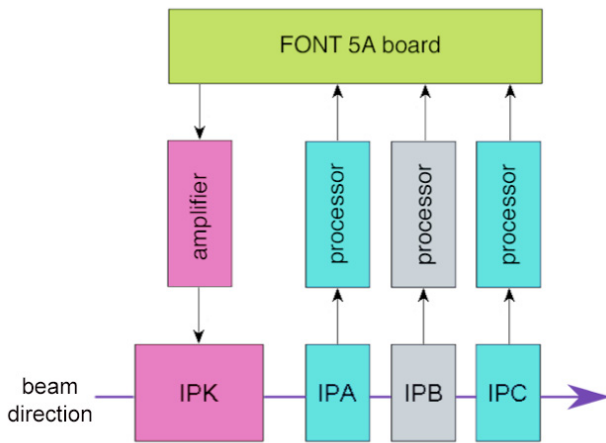

Figure 2: A simplified schematic of the two BPM IP feedback system showing the cavity BPMs (IPA, IPB and IPC), their associated signal processing stages, the FONT feedback board, amplifier and kicker (IPK).

(IPA to IPB, 80.8 mm; IPB to IPC, 174.2 mm) the two BPMs contribute to the feedback in a ratio 32:68, giving an interpolated position resolution, σ_r :

$$\sigma_r = \sqrt{0.32^2 \sigma_{BPM}^2 + 0.68^2 \sigma_{BPM}^2} = 0.75 \sigma_{BPM}$$

where σ_{BPM} is the resolution of one cavity BPM [10], i.e. the position resolution that provides input to the feedback in one-BPM feedback mode. The BPM resolution for this experimental set-up, with 10 dB attenuation on the dipole cavities, was measured to be 74 ± 4 nm.

Another benefit of performing the correction at a third intermediate, non-feedback BPM, is that it provides an independent witness to the correction process.

BEAM TEST RESULTS

Here we summarise the results of beam tests using the FONT5A-generation digital feedback board in two BPM feedback mode at the ATF2.

Accelerator Setup

The accelerator was configured to provide two bunches per pulse of beam extracted from the damping ring, with a bunch separation of 280 ns. This separation was found to provide a high degree of vertical spatial correlation between bunches. This is vital, as feedback tests involve measuring the vertical position of bunch one and correcting the vertical position of bunch two. The system was operated in an ‘interleaved’ mode, whereby the feedback correction was toggled on and off on alternate machine pulses; the feedback ‘off’ pulses thus providing a continual ‘pedestal’ measure of the uncorrected beam position.

The BPM movers were adjusted in the vertical and horizontal planes so the beam passed through all three cavity BPMs simultaneously. To ensure beam jitters were within the BPM’s 5 μm linear operating range, machine optics with a $\beta_y^* 1000$ times larger than nominal were utilised, allowing a much lower divergence of the beam around the IP. What discernible waist remains was then moved closer to IPB by varying the strengths of the two quadrupole magnets, QF1FF and QD0FF, immediately upstream of the IP to produce comparable jitters at IPA and IPC.

IP Feedback

The IP feedback system latency has been measured previously to be 212 ns [11], so well within the bunch train separation time. The performance of the two BPM feedback system was tested using IPA and IPC as inputs to the feedback, with firmware set to stabilise the beam at IPB, where the corrected position is simultaneously measured. Fig. 4 shows the vertical position of both bunches with feedback off and feedback on at IPB. The IP feedback has reduced the vertical beam position jitter of bunch 2 at IPB from an r.m.s. deviation of 253 nm to 83 nm (Table 1). Fig. 5 shows the bunch 2 position versus the bunch 1 position, demonstrating that the feedback system has reduced the bunch-to-bunch position correlation at IPB from 92.2% to approximately zero (Table 1).

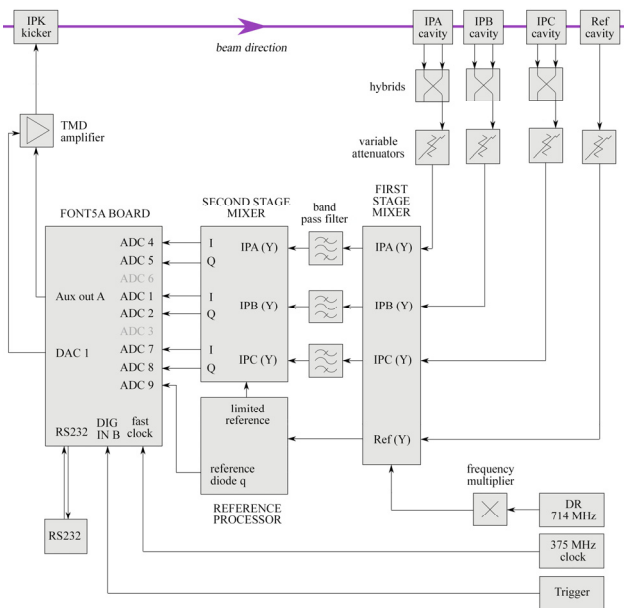

Figure 3: A detailed schematic of the FONT IP hardware configuration for two BPM feedback.

TWO BPM FEEDBACK

In addition to stabilising the beam at a location other than the feedback BPM itself, as in a one-BPM feedback setup, this new feedback mode has the potential to improve the resolution available to the feedback system by utilising information from two BPMs. Given the absence of magnetic fields in the IP region, in the configuration where IPA and IPC are used to stabilise the beam at IPB, the vertical position at the correction point is the weighted average of the vertical positions measured at IPA and IPC (with weights in this instance determined by the distance from IPB). Given the known separations of the BPMs

The feedback has moved the mean position of bunch 2 from $0.92 \mu\text{m}$ to $-3.21 \mu\text{m}$ relative to the vertical centre of IPB. A constant kick offset can be set in the firmware, but for this experiment it did not matter where the beam was stabilised, so this element of the correction was ignored. The different mean positions of bunch 1 and bunch 2 are a consequence of different machine orbits, determined by variations in the damping ring extraction kicker pulse.

A random jitter source installed upstream of the IP was used to introduce large incoming jitters up to $2 \mu\text{m}$ and test the robustness of the feedback. The system performed well up to this level, beyond which large signals begin saturating the electronics, degrading the system resolution, and thus degrading the feedback performance.

Table 1: Position jitter of bunch 1 (σ_{y_1}) and bunch 2 (σ_{y_2}) and bunch-to-bunch position correlation ($\rho_{y_1y_2}$) both with and without the application of the IP feedback correction.

Feedback	σ_{y_1} (nm)	σ_{y_2} (nm)	$\rho_{y_1y_2}$ (%)
Off	265 ± 20	253 ± 19	$+92.2^{+1.3}_{-1.9}$
On	252 ± 19	83 ± 6	-7 ± 10

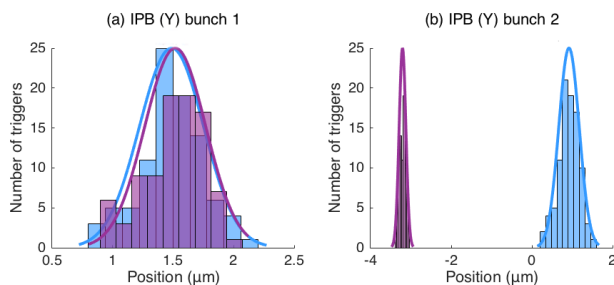

Figure 4: Distribution of the vertical positions of (a) bunch 1 and (b) bunch 2 measured at IPB, with (purple) and without (blue) application of the feedback correction.

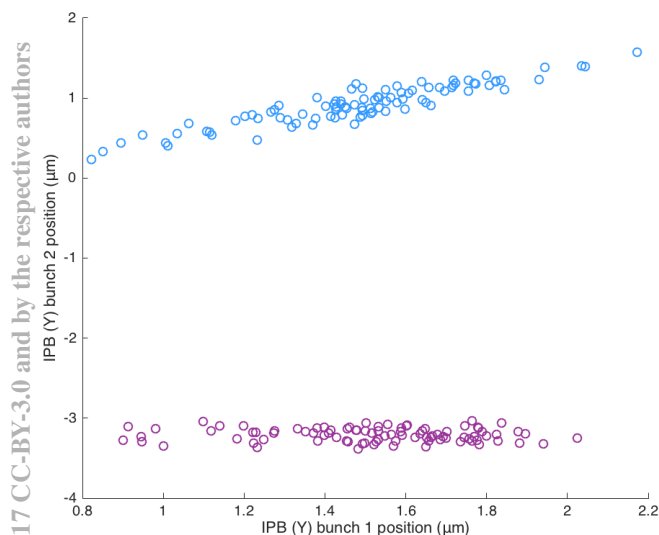

Figure 5: Vertical positions for bunch 2 versus bunch 1 at IPB, both with (purple) and without (blue) feedback.

OUTLOOK

This first trial of a two BPM feedback mode has been successfully demonstrated, but is yet to match the 75 nm -level stabilisation results achieved utilising one BPM, due to difficulties centering the beam in all three BPMs simultaneously and avoiding electronics saturation due to the large jitters with this optics set-up.

We hope to improve the performance of the feedback at the ATF2 through a combination of timing refinements in the electronics, modification of the cavity BPMs to achieve a higher Q, careful digital sampling to maximise bunch-to-bunch position correlation, and operating at lower dipole cavity attenuations to improve resolution.

The FONT5A board firmware currently utilises only one digitised sample point within the BPM pulse. It has been observed that the BPM resolution is improved by integrating several samples in post-analysis. There are plans to implement this in firmware, improving the useable feedback position resolution, and thus improving the FONT feedback performance in all modes of operation.

CONCLUSIONS

Beam stabilisation using two cavity BPMs to correct at an intermediate location has been demonstrated at the ATF2. Vertical beam position stabilisation to 83 nm has been achieved using a local IP feedback system with the correction measured by an independent witness BPM. Work is on-going to improve the resolution of the cavity BPMs and work towards nanometre-level stabilisation.

ACKNOWLEDGEMENTS

We would like to thank KEK for providing the beam time for our experiments, the ATF2 staff for their guidance and support, and our ATF2 collaborators, especially from LAL and KU. Financial support was provided by the UK Science and Technology Facilities Council grant ST/L002620/1 and CERN contract KE1869/DG/CLIC.

REFERENCES

- [1] C. Adolphsen *et al.*, “The ILC technical design report”, volume 3: Accelerator, JAI-2013-001, 2013.
- [2] B. I. Grishanov *et al.*, “ATF2 proposal”, vol. 2, KEK Report 2005-9, 2005.
- [3] N. Blaskovic Kraljevic *et al.*, in *Proc. IPAC’16*, paper THPOR034, pp. 3859-3861.
- [4] N. Blaskovic Kraljevic *et al.*, presented at *IPAC’17*, paper TUPIK110, this conference.
- [5] S. Jang *et al.*, in *Proc. IPAC’16*, paper THOAA02, pp. 3149-3151.
- [6] N. Blaskovic Kraljevic *et al.*, in *Proc. IPAC’16*, paper THPOR035, pp. 3862-3864.
- [7] G. R. White *et al.*, *Phys. Rev. Lett.*, vol. 112, p. 034802, Jan. 2014.
- [8] O. R. Blanco *et al.*, in *Proc. IPAC’15*, paper MOPHA003, pp. 777-780.
- [9] Y. Inoue *et al.*, *Phys. Rev. ST Accel. Beams*, vol. 11, p. 062801, Jun. 2008.
- [10] N. Blaskovic Kraljevic, DPhil thesis, Oxford University, 2015.
- [11] M. R. Davis, DPhil thesis, Oxford University, 2014.